

Company Profile

2024



Seizing Today, Embracing Tomorrow

Exciting Times
Ahead...!

Step into tomorrow with
Rida Middle East
where Innovation
meets Sustainability.

rida
mobile climate solutions



A premium partner to German Technology in the GCC for

- Bus HVAC System
- Thermal Transport Refrigeration
- Bus Interiors
- Service and Maintenance
- Genuine Parts

Rida Middle East, Dubai Investments Park-1, Dubai UAE



www.ridame.ae



+971 50 156 2040 | +971 48 850 496



ridame-ae

Creating Solutions that matter for you, for us & for the environment .

- As a premium partner of global technologies, we catalyze the market, and provide solutions that are drivers of change. We lead the charge in industrializing solutions, built collaboratively with engagement of our customers helping them navigate through, their Key Components selection, design, operative and performance challenges .
- RIDA is GCC's & MENA's largest and only industry certified local content provider for internationally renowned, Automotive Air-conditioning and refrigeration manufacturers of Buses & Trucks, offering an extensive range of integrated, smart and be-spoke solutions. RIDA is established with top-of-the-line sourcing, technical support & manufacturing facilities, at UAE & India.

At RIDA we customize solutions that revolutionize urban transport's climatic needs.

Table of Contents

01

Greetings from CEO	04
About Rida	07
Vision & Mission	08
Meet Our Team	09
History	10

02

Bus Climate Solutions	14
Transport Refrigeration	
Systems	15
Future Plan	16
Service Locations	17
Rida Care	19

03

Workforce	20
Appendix	24
Work with Us	36

Industrialize, Collaborate and Excel.

With our foreign origin brand associations, we have collaboratively given climatic and technology solutions on Buses & Trucks of both Asian, and European origins operating in the region and successfully developed the right solution for all their requirements.



Enter the realm of corporate resilience with RIDA – a narrative where necessity intertwines with innovation, and challenges morph into strategic opportunities.

In today's fluid commercial landscape, where each market shift unfurls a new puzzle, RIDA emerges as a beacon of transformation. Serving as the conduit between technology creators and end-users, our mission is to maximize value across the entire spectrum.

Amidst the relentless pursuit of profitability, RIDA stands apart as a paragon of purpose-driven commerce. From our strategic base in the GCC, we've curated a sterling reputation as the preferred supplier to the region's premier MCV's & HCV's brands, fostering indispensable partnerships with the largest fleet operators.

However, our journey is far from over. Casting our gaze towards the horizon of 2023 and beyond, we envision a future where RIDA not only thrives but also leads the charge in commercial acumen. Our vision is clear: to become the partner of choice for global sales alliances, catalyzing unprecedented growth and delivering compelling returns to our esteemed investors.

At RIDA, our dedication to customer satisfaction extends far beyond the point of sale. We pride ourselves on delivering an unparalleled after-sales and warranty service experience that not only instills confidence but also enhances the performance of our products.

Our commitment to excellence begins with a meticulous attention to detail in every aspect of our after-sales service. From prompt response times to personalized assistance, our team of highly trained professionals ensures that each customer receives the attention and support they deserve.

Whether it's troubleshooting technical issues or providing guidance on product maintenance, we go above and beyond to address every concern with precision and care.

Moreover, our comprehensive warranty program serves as a testament to the quality and reliability of our products.

In essence, our after-sales and warranty service isn't just about fixing problems – it's about delivering peace of mind and ensuring that our customers get the most out of their investment. It's this relentless dedication to customer success that sets RIDA apart and fuels our continued growth and success in the market.

By leveraging data-driven insights and predictive analytics, we anticipate potential issues before they arise, thereby minimizing downtime and maximizing productivity for our customers.

In the realm of business, quality isn't just a benchmark – it's a guiding light illuminating our path to greatness. At RIDA, we breathe life into this ethos, infusing every endeavor with an unwavering commitment to excellence.

Beyond mere adherence to standards, we embody a culture of continuous improvement, pushing the boundaries of possibility with every stride. Quality isn't a destination; it's a relentless pursuit, a journey marked by perseverance and passion.

As we navigate the challenges ahead, let us embrace each obstacle as an opportunity to showcase our dedication to quality. Let us forge ahead with courage and conviction, knowing that our unwavering commitment to excellence will pave the way for enduring success.

In the end, it's not the accolades or achievements that define us – it's the quality of our character, the depth of our integrity, and the steadfastness of our commitment to excellence. Together, let us build a legacy of quality that transcends time, inspiring generations to come to reach for the highest standards in all they do.

Our success is not merely quantified by financial metrics; it is deeply entrenched in our core values. Integrity, responsibility, excellence – these pillars underscore every facet of our operation, resonating with investors who seek purpose-driven ventures that transcend mere profit margins.



To our esteemed investors, we extend a warm invitation to embark on this journey with us. Let us collectively shape the future of mobility, leveraging the boundless opportunities that lie ahead. At RIDA, the narrative is as captivating as the destination, and we invite you to be an integral part of our corporate odyssey.

Central to our success at RIDA is our longstanding partnership with leading technology manufacturers, who stand as our preferred collaborators in the realm of innovation. Rather than reinventing the wheel, we recognize the value of leveraging the expertise and resources of these esteemed partners. Our approach of partnerships not only ensures a steady stream of top-tier products but also fosters a culture of mutual respect and shared success within the industry.

As we continue to navigate the dynamic landscape of modern commerce, our commitment to these valued partnerships remains unwavering, serving as the cornerstone of our collective journey towards sustained growth and prosperity.



Yazdani Qureshi

Founder & CEO



Intro

About RIDA*

Seizing Today, Embracing Tomorrow..

RIDA is a first-generation pioneer in technological solutions, that re-define convenience, comfort and sustainability across various segments of automotive engineering. As collectively the world today is moving towards greener and a cleaner tomorrow, RIDA through its products and services inculcates quality, critical design and performance enhancement's, value additions essential to key component performances.

- RIDA Mobile Climate Solutions: A portfolio of comprehensive thermal management solutions, ranging from ACs to Refrigeration systems for Buses and Trucks.
- RIDA Services: An enhanced portfolio of services with focus on quality, design deliverables and skill engagement, to improvise product performance and efficiencies.



Company Profile

Vision & Mission



To become a global specialist in providing automotive solutions, for a better tomorrow, a sustainable future and continuous innovation. Develop solutions that inspire brands to instigate change, redraw business processes, better manage resources and fulfill all value additions. Re-invent and develop a tailored ecosystem for transport of people, product, its storage and their handling, with the help of advance technologies and resource management systems.

- Become MENA’s largest mobile climate solution provider.
- Preferred OE supplier to all European Bus & Truck Makers
- Key Component Manufacturing.
- Largest After sales and Service Network in GCC
- Digitized, advanced technological systems pioneer.



Partner with the leading and pioneering global technological brands.



Innovation in service and customer care. Focus on after sales value additions.



Hire & Retain, the best innovative and driven talent.

Meet Our Team

A dynamic and seasoned team, brimming with enthusiasm, innovation and drive. With fresh perspectives and boundless energy, we tackle challenges head-on, delivering results that exceed expectations every time. We are a team driven with a visionary leadership, and an infinite desire to serve and succeed.



Samdani Qureshi
General Manager



Iftekhar Alam
Chief Technology Officer



Ghulam Jeelani
Group Financial Controller



Abdul Samad
Business Development
Manager - GCC



K. Shankar
Sales & Marketing Manager -
GCC



Shamnas Rahman
HR & Administration Manager



Rajesh Bhukya
Key Accounts Manager



Ravindra Singh
Deputy Design Manager

Milestones

The Past 8 Years

Last 8-years have been remarkable in RIDA's journey, RIDA has undoubtedly emerged as a global leader. The focus points in the last decade for the company was to prioritize organic growth, diversify its product portfolio, expand services, and invest in cutting-edge technology. Guided by a cohesive team, RIDA's unwavering commitment to excellence propelled it to the forefront of innovation & successfully achieve all key milestones

A successful longstanding brand is more than just a name; it's a legacy built upon historical actions and foundational principles. Each decision, from humble beginnings to iconic milestones, shapes its identity. Historical actions create a narrative that resonates with consumers, fostering trust and loyalty.

Meanwhile, foundational principles, like integrity and quality, establish the brand's reputation and set standards for excellence. Over time, this consistency cultivates a strong brand identity that withstands challenges and evolves with the times. By honoring its past while embracing innovation, a longstanding brand embodies authenticity, inspiring generations and standing the test of time.

● 2016

Embracing industrialization, RIDA underwent a transformative journey, optimizing processes, increasing efficiency, and scaling production. This evolution not only bolstered economic benefits, fostering growth and competitiveness but also positioned us as a driving force in our industry's landscape.

● 2017

Established as UAE's largest aftersales service and preventive maintenance contractor, for public transport climate systems, with over 1200 Buses in AMC.

● 2018

During the Consolidation and Expansion phase (2017–2018), RIDA achieved remarkable milestones: steady customer base growth driven by exceptional product experiences, substantial infrastructure upgrades enhancing technological capabilities, all while doubling the team size with diverse talent, and placing significant emphasis on aftersales support and comprehensive warranty coverage.

150 members strong team, 25,000 sq.ft Production facility, Local presence in 6 countries, achieved 100 million USD + in Business Transactions up to date, successfully created a customized product line, for every bus make.

● 2019

2021 marked a transformative event as RIDA strategically embraced collaboration for growth. This epochal partnership with prominent brands such as Valeo, propelled us towards unprecedented success, forever shaping our legacy as a dynamic and visionary industry player.

● 2021

Introduced new brand identity of RIDA, a representation of our infinite desire to serve, infinite dreams, penchant for hunger and noble glory. Achieved remarkable feat of catering over 5129+ Qty supplied under warranty, 8 permanent stations of onsite support, Up to 53 locations covered in service network, with 6 mobile teams.

● 2022

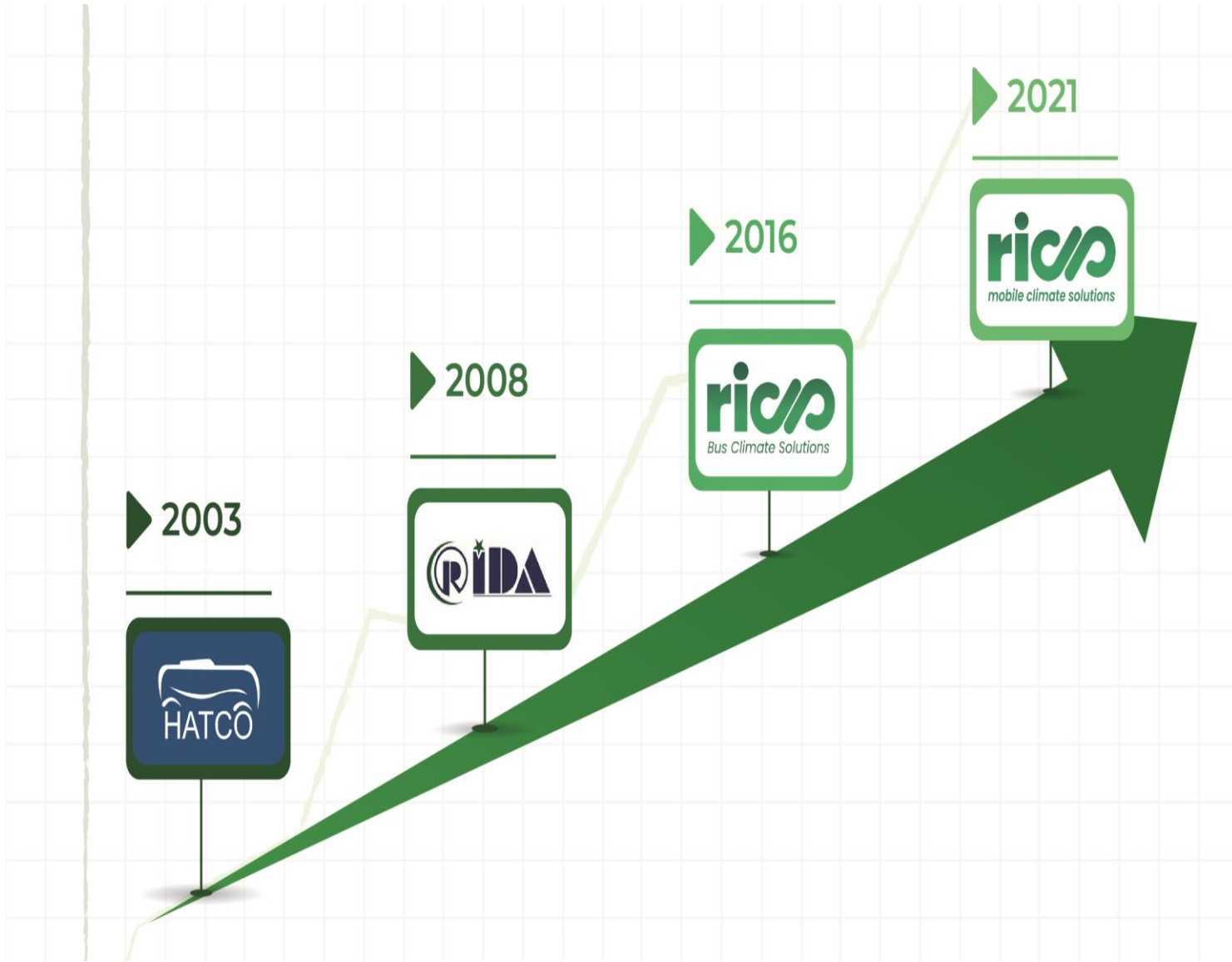

Business must be the solution, not the problem. We will be defined by not what we achieve, but how we survive, strive & succeed- RIDA

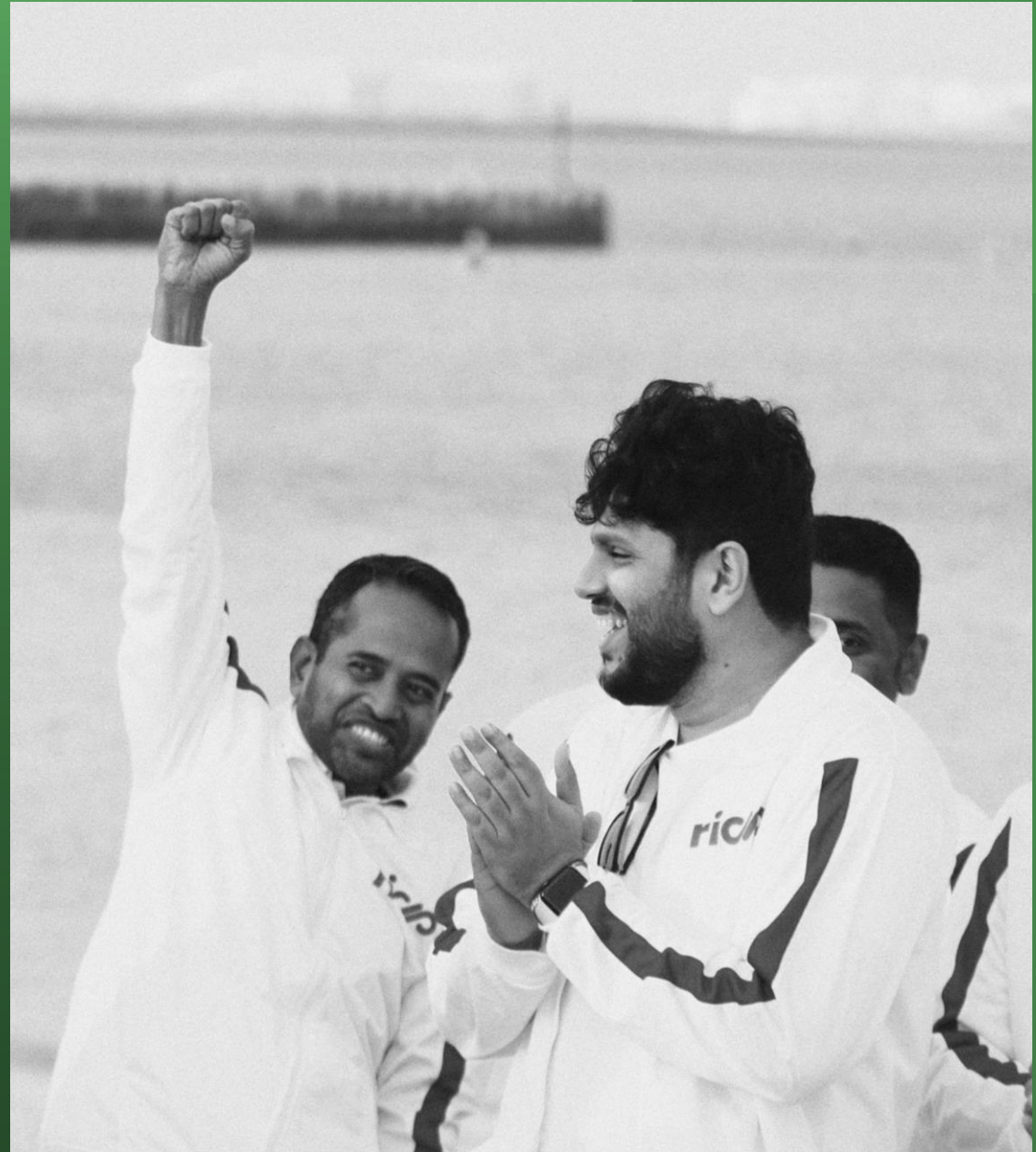

Value-Driven Solutions: Enhancing Partnerships Across Industries.

We understand that exceptional customer service and customized solutions are paramount in driving success and fostering long-lasting relationships.

Our value-added approach extends beyond product delivery, encompassing a range of services aimed at enhancing efficiency, reliability, and overall operational excellence. From customized component designs to specialized testing and validation processes, we go above and beyond to deliver solutions that drive tangible results and deliver measurable value.



Bus Climate

Finest Thermal Management for Buses and Trucks: AC systems supplied by RIDA, are the largest in use application for on road passenger cooling, built for the rough and unforgiving hot terrain of the Middle-east.

RIDA offers Air conditioning products, for chassis ranging from 4-tonne to 24-tonne Gross Vehicle Weight (GVW) mainly, small, medium, and large buses, coaches and passenger vehicles. The fusion of meticulous engineering and top-tier materials guarantee cooling excellence, product performance and fleet savings, that lasts over decades

MPE Heat Exchangers for Minimal Freon Consumption and compact designing, consume 3.5 KG/ Per system less freon compared to traditional copper heat exchangers align perfectly with our mission to create aesthetic looking, and eco-friendly sustainable solutions that preserve our planets and operators' resources.

Our product design and KIT combination ensure unparalleled passenger comfort with unwavering reliability. Building bespoke climate solutions for the customers is our expertise.

Sustainability is a critical goal that We strive to achieve across all our products & services.



An UITP active member



MODULAR CONCEPTS FOR GLOBAL BUS MARKET



MINI- / MIDI BUS



CITY BUS



SCHOOL- / TRANSIT BUS

Air conditioning solutions
COMFORT AND FEEL-GOOD

Tailor-made cooling concepts for all markets, customers, bus drives and sizes

- Roof top split units at high cooling performance 4kW - 50kW
- Lightweight - long life - low noise emissions - minimized refrigerant charge
- Integrated high voltage compressor with frequency inverter, variable adjustment
- Optional with heating, fresh air, front box connection or heat pump plus de-icing function up to -10°C



Transport Refrigeration

Enhancing Supply Chains: Cold Chain Logistics, Smart Temp Control.

We are the region's first and only holistic, Transport Refrigeration Provider, with a product range covering all requirements of temperature management from point of production to consumption.

RIDA TTR Systems, aim to improve overall food freshness through smartly managed transport and storage of perishable goods.

Re-invent and develop a tailored ecosystem for transport of your product, its storage and handling, with the help of advance technologies and resource management systems

Equipped with automatic electronics systems that deliver an unrivaled level of sophistication in efficient product management. These systems facilitate seamless, autonomous operation of both the engine and rooftop unit, allowing drivers & supervisors to have better control over machine output. The onboard intelligent system management makes possible significant fuel savings and a greener environment.



DIESEL ELECTRIC



EUTECTIC SYSTEMS



DIRECT DRIVES



TRAILER



CRYOGENICS

Transport Refrigeration
EXPERTS IN COOLING

Transport refrigeration equipment is designed to maintain constant temperature of perishable goods in an insulated box with -25°C to +10°C from point of loading to point of dispatch.

Safety and reliability are most demanding needs in this segment to finally meet end consumer's interest of **fresh food and safe medication.**

Future Plan

Re-think , Re-design, Re-work – Restart with RIDA.

Re-thinking the Choices we make

- Box Manufacturing & Wire Harnesses – Rida seeks to manufacture boxes and wire harnesses in-house to be more cost and energy efficient and be the torch bearer in driving innovation in materials, manufacturing processes, and automation technologies.
- Annual Maintenance Contracting – Rida as of now has over 700 AC units under its AMC program and over 1200 AMC contracts in the pipeline to be finalised by year end.
- Service App – Rida has launched a service app that provides its users service reminders, appointment scheduling features and technician's dispatch – all just at a click of a button.
- Localization & Emiratization - Rida aims to localize key manufacturing inputs and hire 40% of total workforce as Emiratis in critical key decision-making roles.

Addressing challenges to sustainability, by re-evaluating key component designs, processes, functions, operations and our choices as technology enthusiasts.

Towards a Sustainable Future.



Branch Office

Us Across The MIDDLE EAST

Expanding our footprint strategically to better serve our clients' needs. Our offices are more than just spaces; they're hubs for collaboration and innovation. We're committed to being where our clients are, ensuring accessibility and proximity. Stay tuned for updates as we continue to grow and establish new branches globally.



UAE

KSA

Bahrain

Kuwait

Oman

Qatar

Customer Centricity: Customer Journeys at Scale.

- **Definition:** We actively listen to our customers’ feedback and have established robust communication channels following a front to back approach by conducting surveys and analyzing data to ensure that customer demands are effectively relayed and met at all levels.
- **Design:** All our actions and policies are zero based and future proof.
- **Governance and Funding:** Rida has a persistent funding model, focusing on enabling teams and operations.
- **Enabling and Execution** of people, processes and talent with accelerated delivery of MVP’s. The above, with personalized solution making, responsive communication and an over all culture of continuous development, is how Rida plans to exceed all expectations.

CUSTOMER CENTRICITY

The Prime Focus

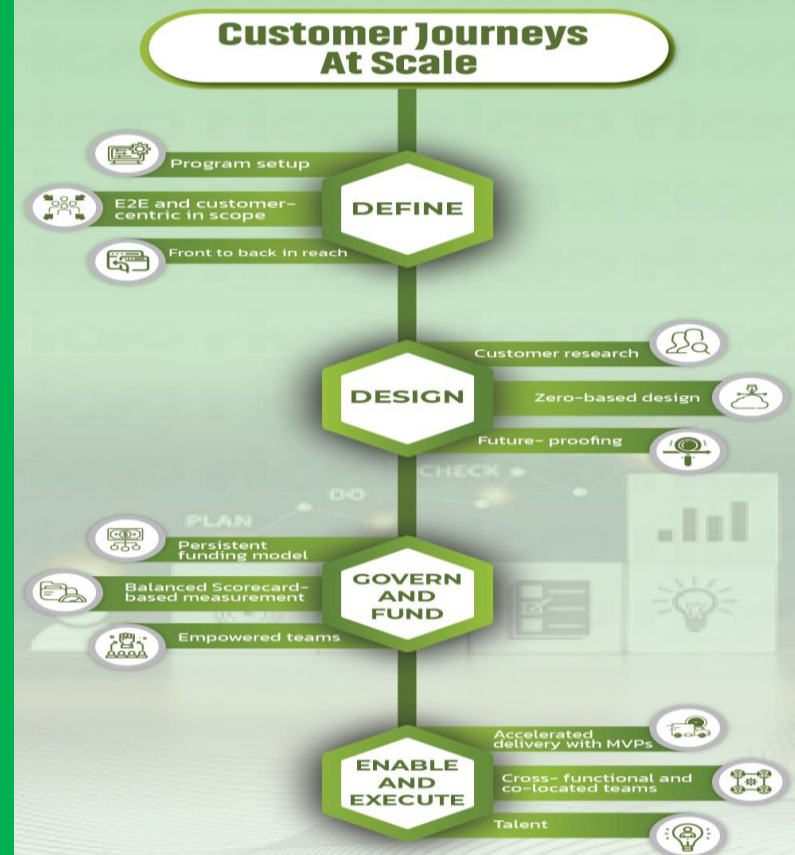

Rida Care

A Vision Through Passion;

Portfolio of support systems designed exclusively for your industry's needs.

Acknowledging the need for balance between product quality & service .

The true purpose and performance of a product can be achieved only when the servicing aggregates of products in use are well maintained, as per the manufacturer guidelines. We at RIDA understand the importance of the right technical attention needed for your products longevity and benefits of scale.

We understand the unique challenges faced by the transportation industry, and our experts are equipped to handle them with precision and care. This advancement in technical support brings a new level of convenience, specialization, and uniqueness to your fleet management.



**Intelligent Management:
Towards Automization**

Maximize the value of your investment by partnering with RIDA. ensuring the product functions optimally throughout its lifespan.

Portfolio

An Innovative **Workforce**

200+ Strong Dream Makers

Skilled Technical Experts .

Technical experts ensure precision, reliability, and problem-solving prowess. Their innovative thinking drives creative solutions, leading to improved service quality and cost savings. Our dreamers personalize services to enhance the customer experience, fostering loyalty. They also play a crucial role in compliance and manufacturer processes implementation, ensuring our solutions are validated. Our seasoned professionals bring a wealth of knowledge and a deep understanding of real-world challenges. With years of hands-on experience, they can foresee potential issues, optimize solutions, and adapt swiftly to changing circumstances.

Think Smart. Beyond the Ordinary

Critical thinking acumen is the cornerstone of our success in the technical field and cultivating it within a supportive work environment yields significant benefits. We motivate critical thinkers to excel at analyzing complex problems, making informed decisions, and innovating solutions.

01.

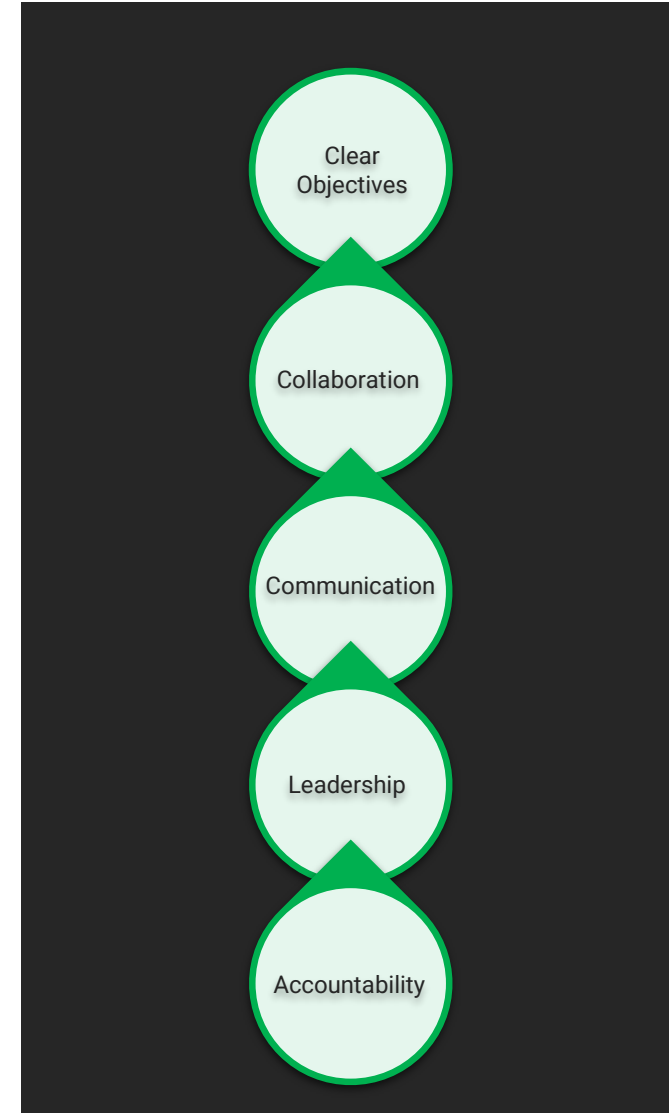

Corporate Culture

Our team embodies collaboration, innovation, and continuous learning, cultivating an environment of empowerment and value. Our strategic partnerships with customers and suppliers prioritize understanding individual needs, exceeding expectations, and positive-sum relationships.

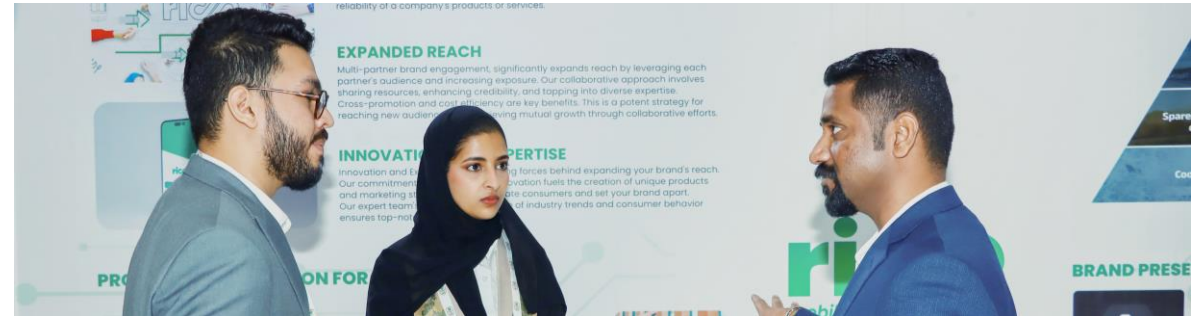

Stakeholder Relationships

Our strategic supplier partnerships prioritize collaboration, transparency, and mutual success, fostering resilience and efficiency across our supply chain.



TEAM BREAKDOWN

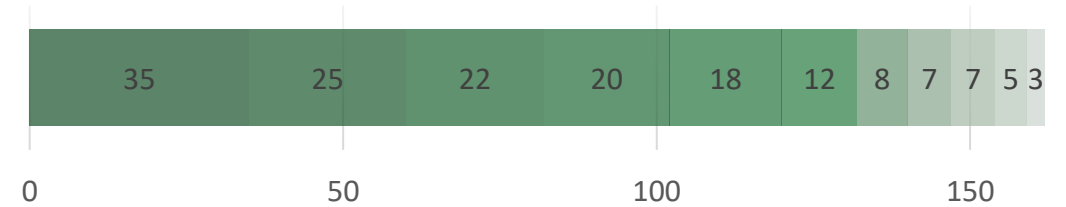

- Mechanics
- Auto Electricians
- On-road Support
- Skilled Helpers
- Ducters
- Wiring Techs
- Welders
- Lathe Operators
- Mechanical Engineers
- Service Executives
- Electronics Engineers

Data Management

Efficient ERP system implemented with a data warehouse guiding data-driven decision making.

Inventory & Supply Chain

Over 50 different components under warranty and on average \$10 M stock at hand year-round. Supply chain spanning over 7 countries.

8,000 Buses under warranty and growing...

Company Profile

Seizing Today,
Embracing Tomorrow.

www.ridame.ae



Unleashing Synergy

Powering Growth with Unmatched Partnerships!

PREMIUM SALES PARTNER



AFFILIATED PARTNERS



Certified Premium Sales Partner

SPHEROS

formerly known as **Valeo**

SPHEROS

AUTHORIZED SALES AND SERVICE
CERTIFICATE

This is to certify that

RIDA Middle East

is our

PREMIUM PARTNER

appointed by
Spheros Germany GmbH

2024

Gilching, 5.08.2024

Place, Date

M. Sander
Mark SONDERMANN
CEO Spheros Group

moving thermal future

www.ridame.ae

Distinguished Customers

63,000 buses transformed and over 300+ satisfied customers





A tour

Product Portfolio



Electronics

Parts/Accessories

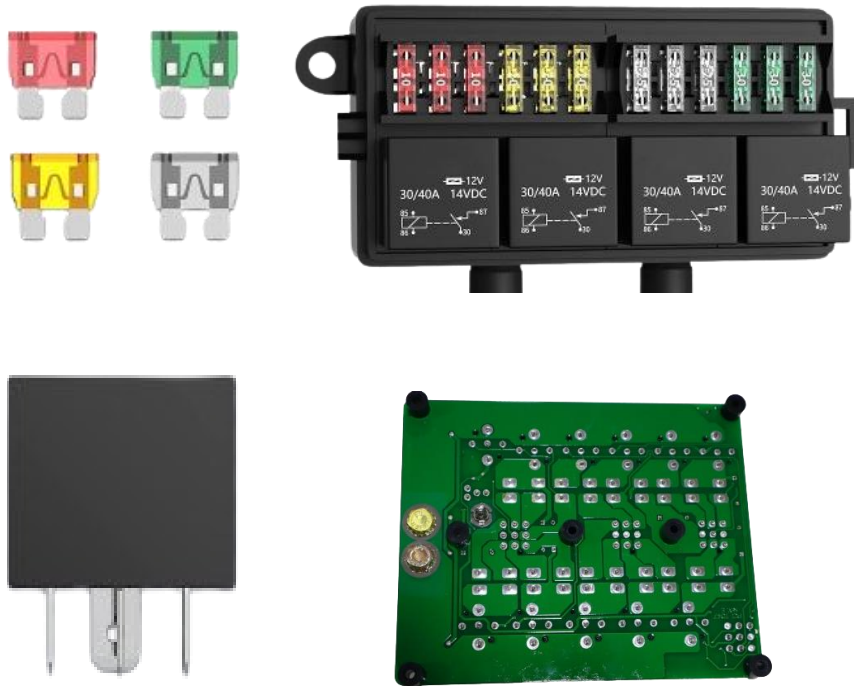

Component



Auxiliary Engine Assembly

Parts/Accessories

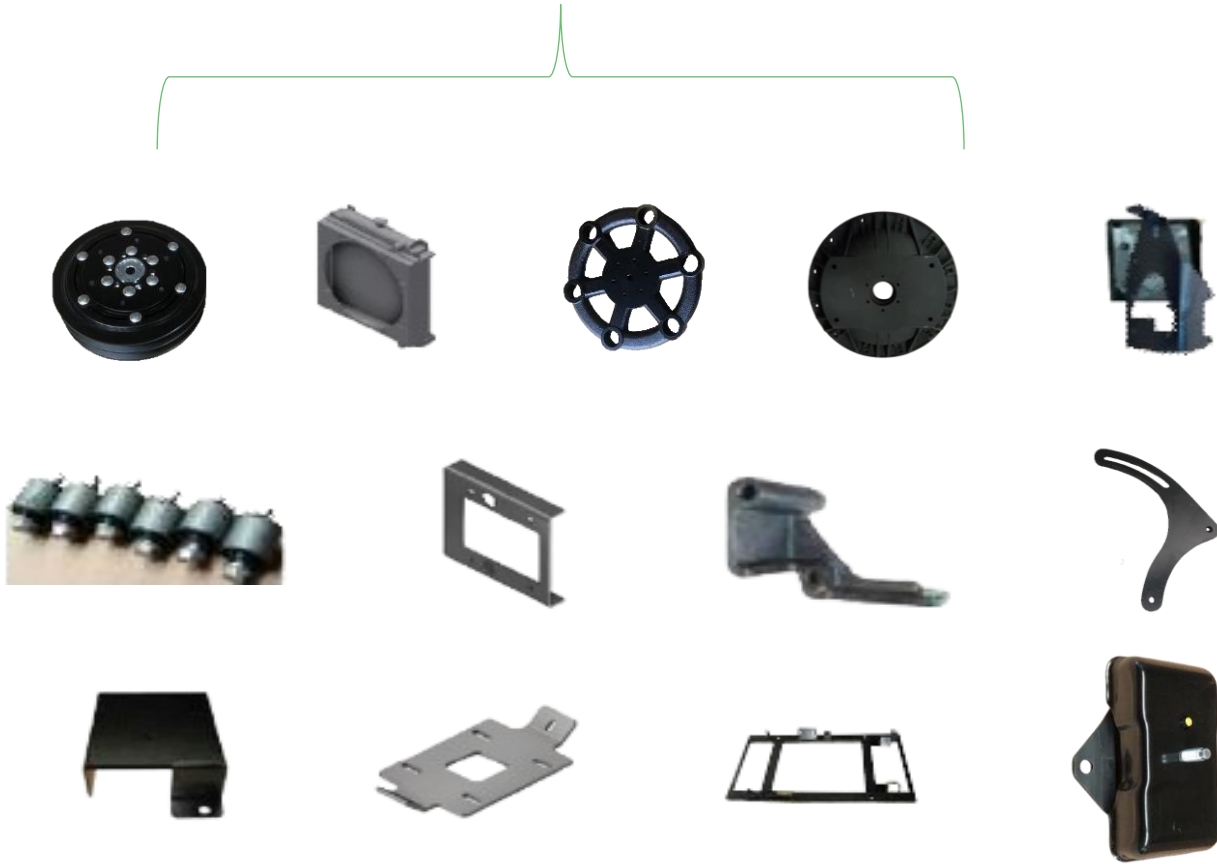

Component

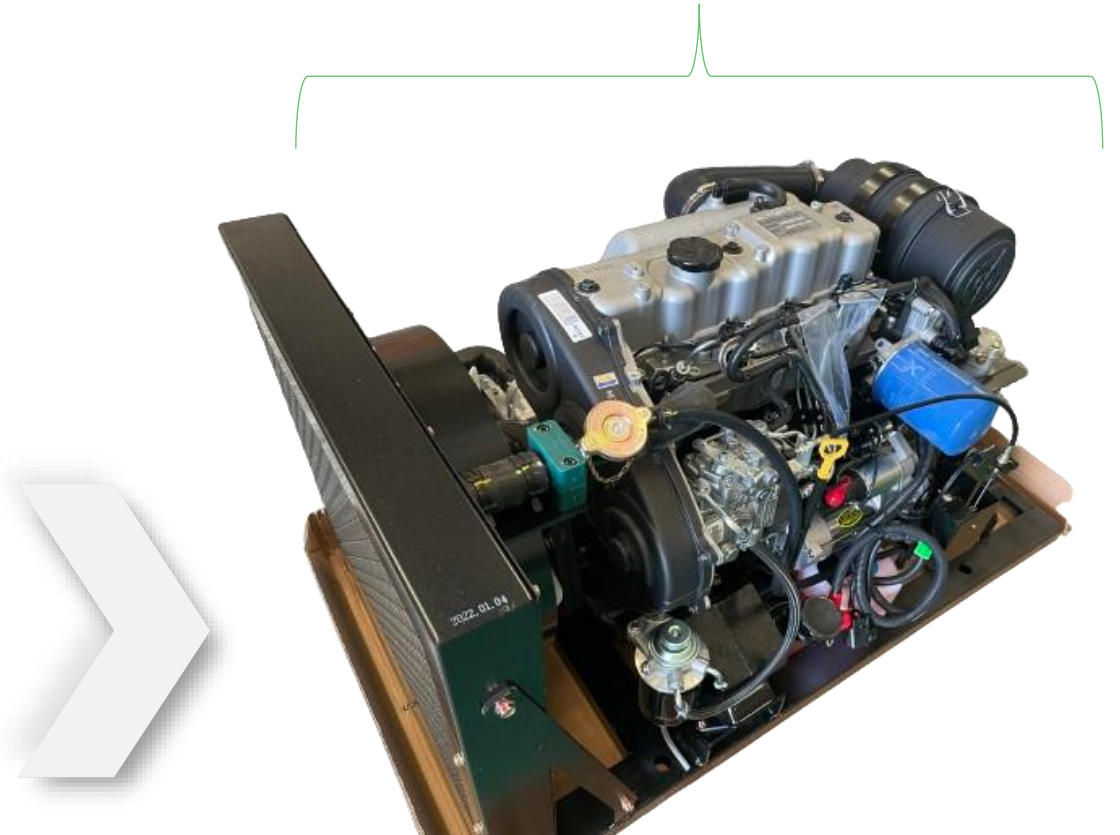

Mobile Climate Solutions

Parts/Accessories

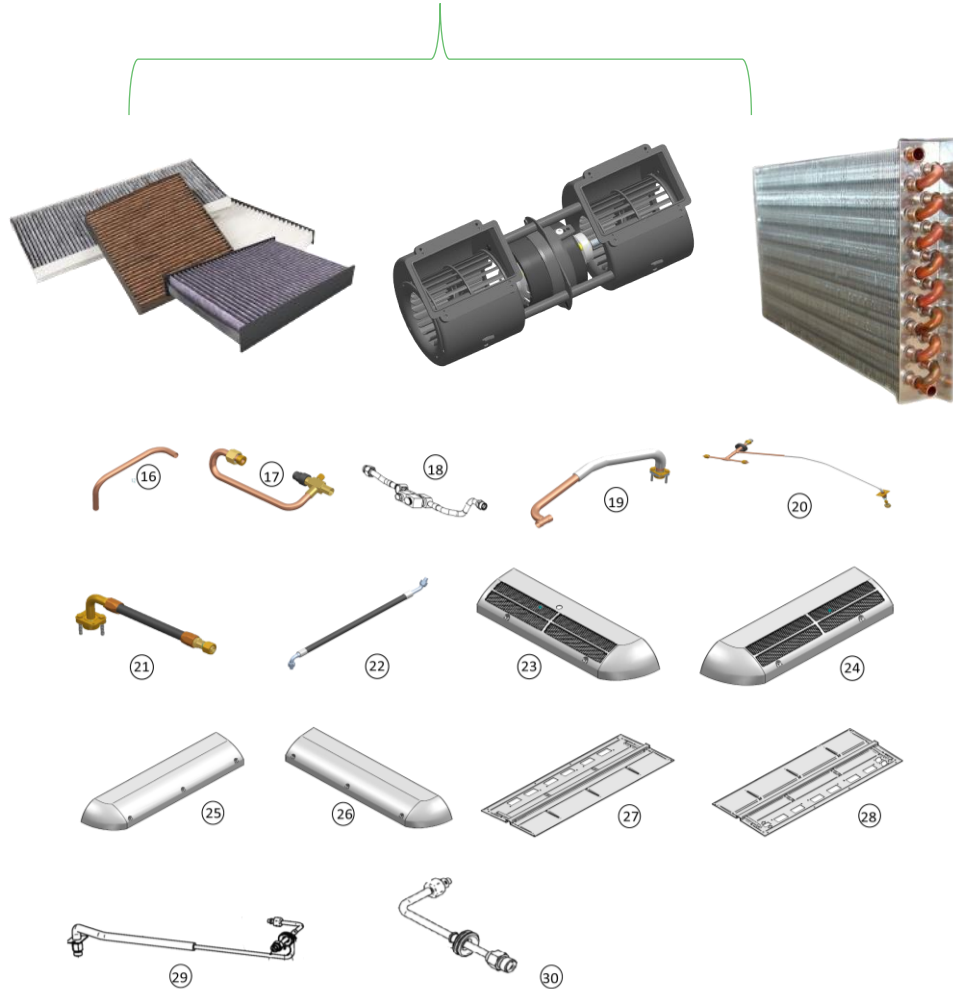

RIDA*

Component

AC UNITS



MIDISPHERE



CITYSPHERE



R744



CC355

SAFETY HATCHES



MEGAVENT



MODUS CITY



SMART



ELEON

REEFER SYSTEMS



KOOLVAN



MT LINE



KOOLTUBE



VT180

Wiring Harnesses

Parts/Accessories



Component

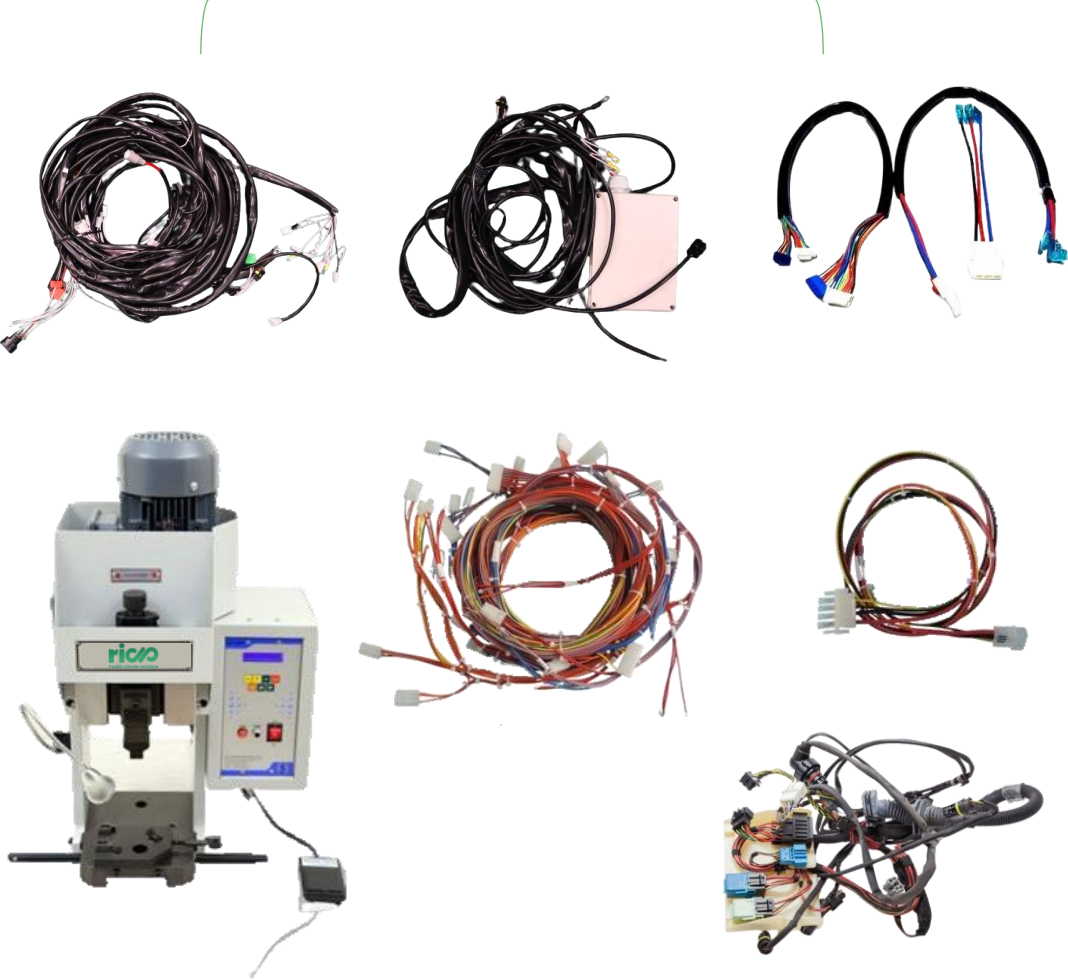

Thermal Transport Refrigeration

Parts/Accessories

Component

Lightweight GRP Sandwich Panels

Aluminum Corner Cap



Box Body Aluminum T Styling Skirts

Insulated Refrigerated Body

Aluminum Fender Bar

FRP Wall Panel – Smooth & Moisture Proof

Rear Parking Sensors

RIDA*

PVC Strip Curtains



Service App Developed

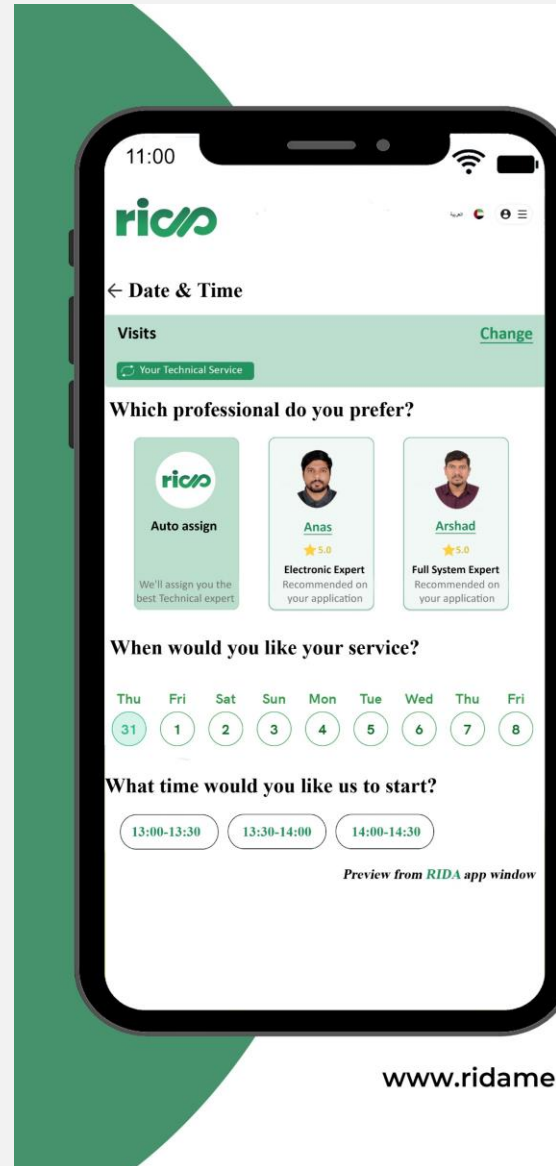

Dr. Cool Care **RIDA Comprehensive Service App for BUS & TRUCK Climate Care**

Launching soon RIDA App, will allow users to order Skilled Transport Climate Experts on Demand, for across the board technical solutions.

- ✓ Order Skilled Transport Climate Experts On-Demand
- ✓ Warranty on Service
- ✓ Specialized solutions for all systems and makes.
- ✓ 100% Genuine Part Assurance
- ✓ Quickest Turnaround time Guarantee



www.ridame.ae

info@ridame.ae

Annual Maintenance Contracting

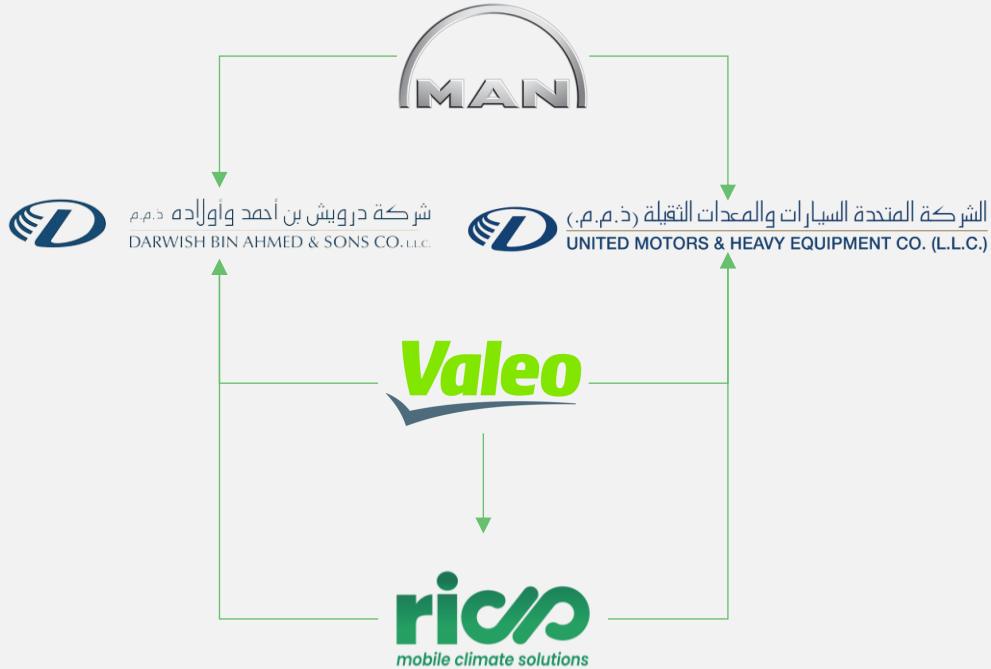

700+ AC Units under AMC



1000+ AMCs to be finalized by year-end

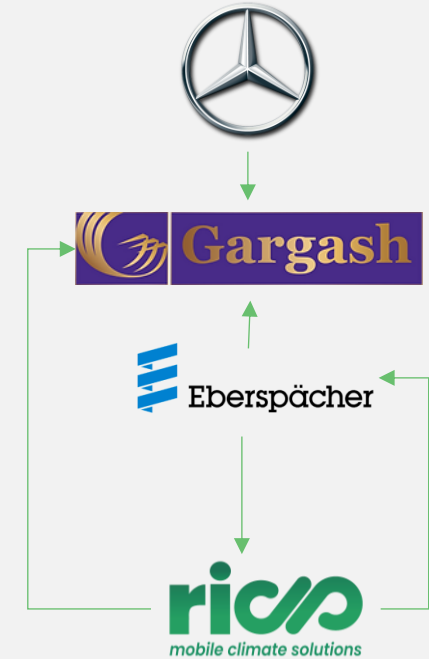

160 AC Units under AMC

Summary

Work With Us

Ready to elevate your passengers' experience with superior climate solutions?

Join us in tailoring bus climate solutions perfectly suited to your needs in the arid Middle East region. Let's collaborate to ensure optimal comfort and efficiency for your passengers.

Connect with us today to embark on a journey of enhancing customer satisfaction and driving success together.

Join Us for Exclusive Benefits

Experience unparalleled after-sales service and innovative climate solutions, where your needs are our priority. Join us in creating value as we pave the way for a sustainable future.

Engage with Us for Mutual Success

Tap into strategic partnerships tailored for mutual success. Embark on our journey to surpass expectations, pioneer innovation, and deliver exceptional value to all stakeholders.



Warehouse # 2, Dubai
Investment Park 1, P.O.Box: #
49357 Dubai (U.A.E)



1-800-456-RIDA
1-800-456-FAXIT



info@ridame.ae
www.ridame.ae



[https://ae.linkedin.com/company/
ridame-ae](https://ae.linkedin.com/company/ridame-ae)